

# **HAHN**

**& SOHN**

## **H IG 2400**

**QUIET INVERTER PETROL  
GENERATOR**

Operating instructions

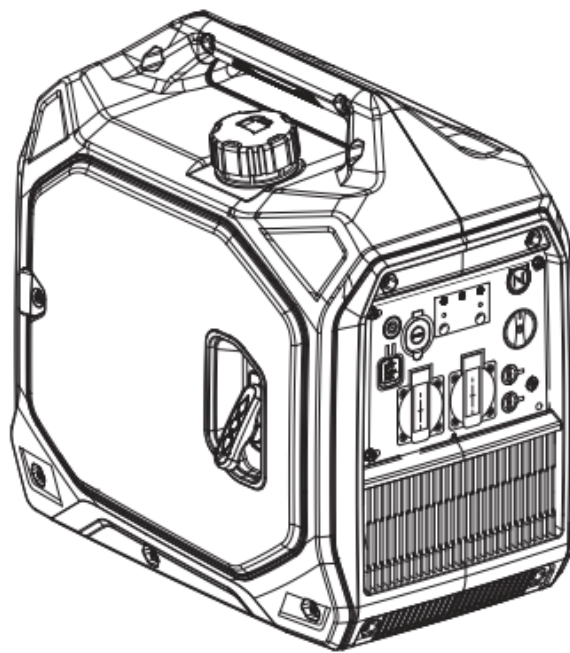

# Contents

- SAFETY WARNING ..... 3
- 1. SAFETY INFORMATION ..... 4
- 2. LOCATION OF IMPORTANT LABELS ..... 6
- 3. DESCRIPTION ..... 7
- 4. CONTROL FUNCTIONS ..... 8
- 5. PREPARATION ..... 9
- 6. OPERATION ..... 11
- 7. MAINTENANCE ..... 16
- 8. STORAGE..... 21
- 9. TROUBLESHOOTING ..... 23
- 10. SPECIFICATIONS ..... 24
- 11. WIRING DIAGRAM ..... 25

Thank you for choosing our company's silent inverter generator.

All information in this publication is based on the latest product information available at the time of printing. The contents of this manual may differ from the actual parts due to revisions and other changes.

Our company reserves the right to make changes at any time without prior notice and without any obligations. No part of this publication may be reproduced without the written consent of our company.

This manual should be considered a permanent part of the generator and should be included with the generator in the event of resale.

## SAFETY WARNING

The personal safety and security of your property and that of others is very important.

Please read these warnings carefully, which are marked with the symbol  or **NOTE**.

### **DANGER**

Failure to follow the instructions **MAY RESULT IN DEATH or SERIOUS INJURY.**

### **WARNING**

Failure to follow the instructions **MAY RESULT IN DEATH or SERIOUS INJURY.**

### **NOTICE**

If you do not follow the instructions, you **MAY BE INJURED.**

### **NOTE**

Failure to follow the instructions may result in damage to the generator or other property.

## 1. SAFETY INFORMATION

Read and understand this manual before operating the generator. Familiarising yourself with safe operating procedures will help prevent accidents.

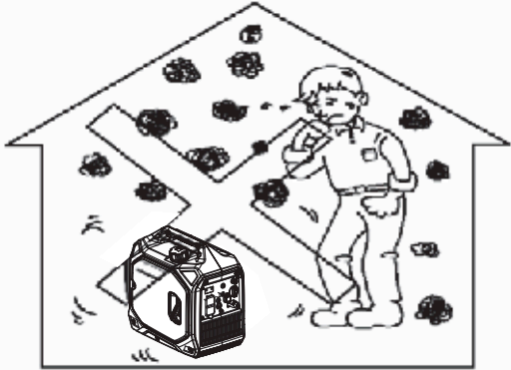

Never use indoors

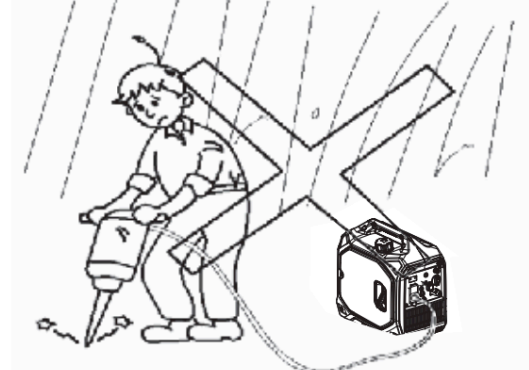

Never use in damp environments.

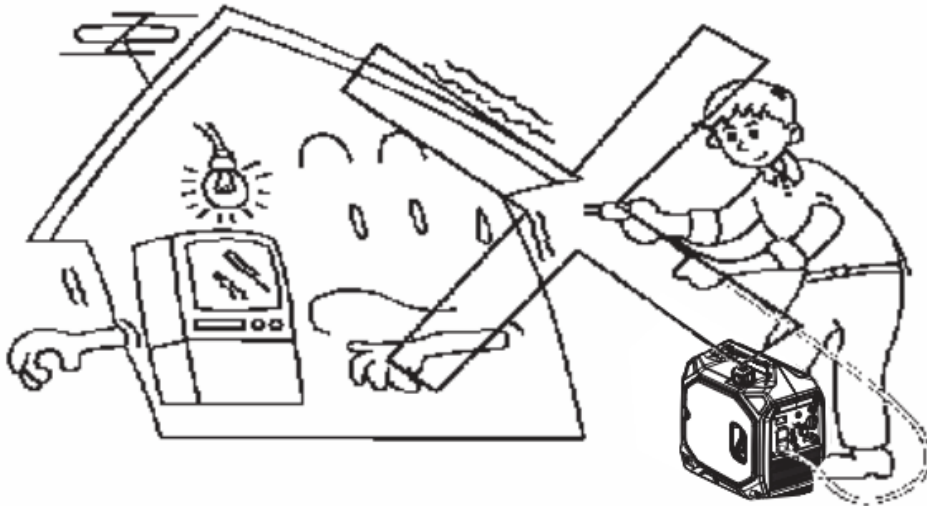

Never connect it directly to your home electrical system.

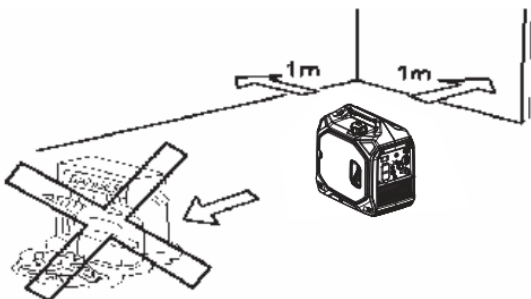

Keep it at least 1 metre away from flammable materials.

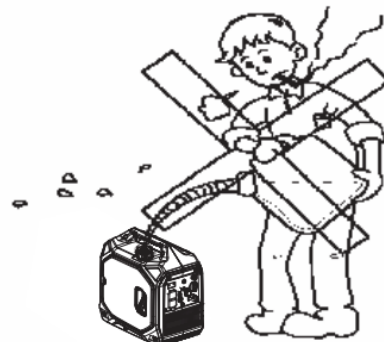

Never smoke while refuelling.

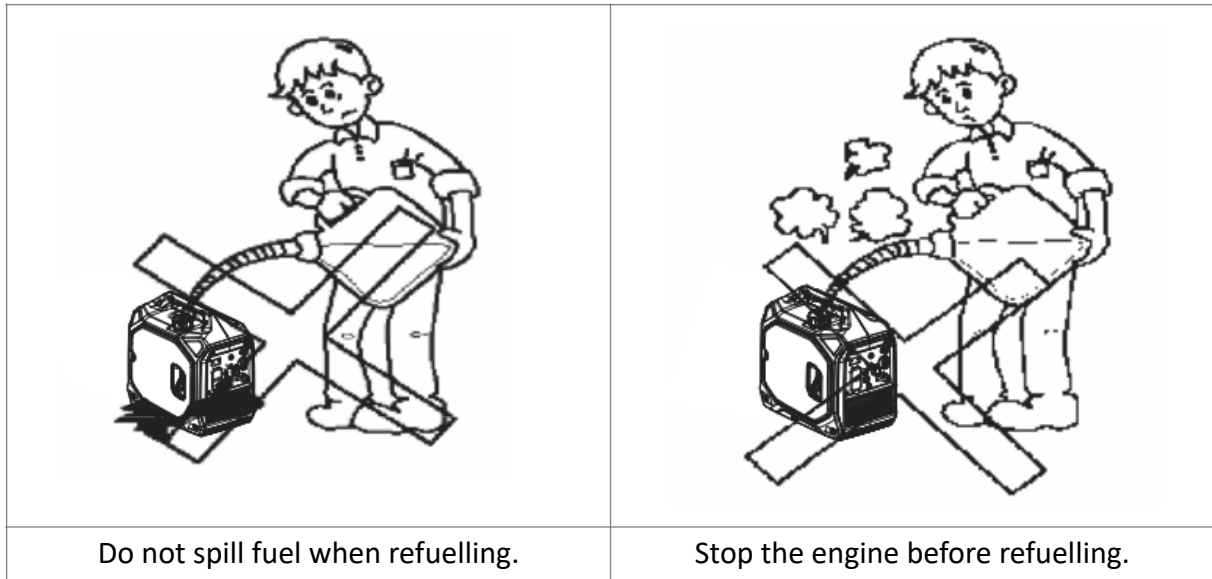

### Connection to a domestic power supply

#### NOTE

If the generator is to be connected to a domestic power supply as a backup source, the connection must be made by a professional electrician or other person with expertise in electrical engineering.

After connecting the loads to the generator, carefully check that the electrical connections are safe and reliable. Incorrect connections can cause damage to the generator or a fire.

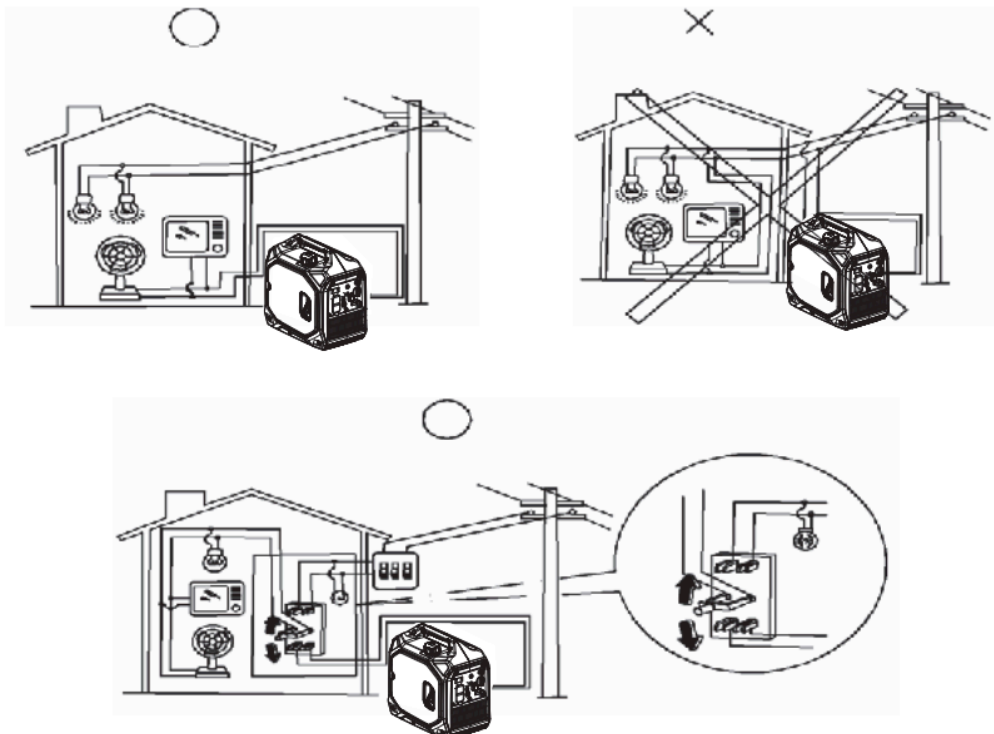

### Grounding the generator

To prevent electric shock due to poor-quality electrical appliances or improper use of electricity, the generator must be grounded using a high-quality insulated conductor.

**NOTE**

Ensure that the control panel, grille, and underside of the unit are not blocked and that no debris, mud, or water can enter them. If the cooling vent becomes blocked, the motor, converter, or alternator may be damaged.

Do not connect anything when moving or storing the unit. Doing so could damage the generator or compromise safety.

## 2. LOCATION OF IMPORTANT LABELS

Before operating this machine, carefully read the following labels.

TIP: Maintain or replace safety and instruction labels as necessary.

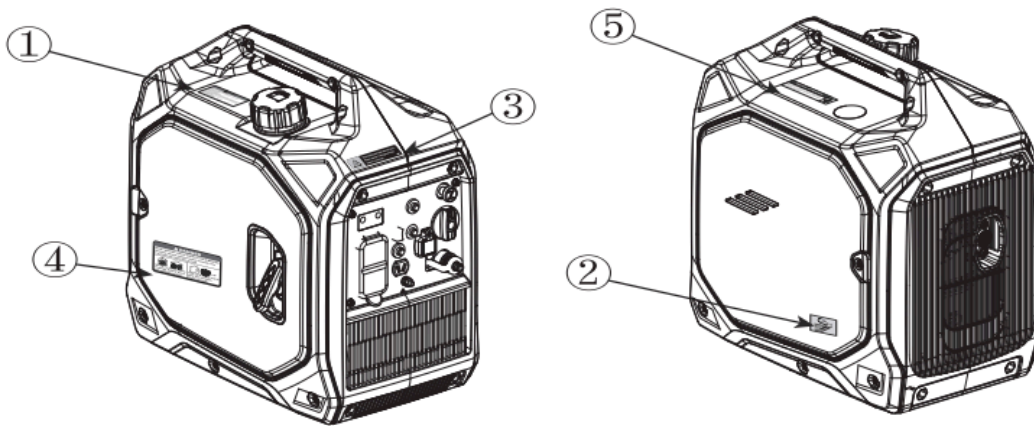

① **WARNING**

- Read the owner's manual and all labels before operating.
- Only operate in well-ventilated areas. Exhaust gas contains poisonous carbon monoxide.
- Check for spilled fuel or fuel leaks.
- Stop engine before refueling.
- Do not operate near flammable materials.
- Electrocutation can occur if generator is used in rain, snow, or near water. Keep this unit dry at all times.
- Electrocutation or property damage can occur. Do not connect this generator to any building's electrical system unless an isolation switch has been installed by a licensed electrician. Refer to the owner's manual.
- When operating the generator:
  - Never place a partition or other barrier around the generator.
  - Do not cover the generator with a box.
  - Do not place any objects on the generator.
- Turn the fuel tank cap air vent knob to 'OFF' after the engine has completely cooled down.

② ③

**Hot exhaust can burn you. Stay away if engine has been running.**

④ **DANGER**

Using a generator indoors CAN KILL YOU IN MINUTES. Generator exhaust contains carbon monoxide. This is a poison you cannot see or smell.

NEVER use inside a home or garage, EVEN IF doors and windows are open.	Only use OUTSIDE and far away from windows, doors and vents.

⑤ **NOTICE ATTENTION**

- Use the specified spark plug only.
- Recourir exclusivement à la bougie du type spécifique

### 3. DESCRIPTION

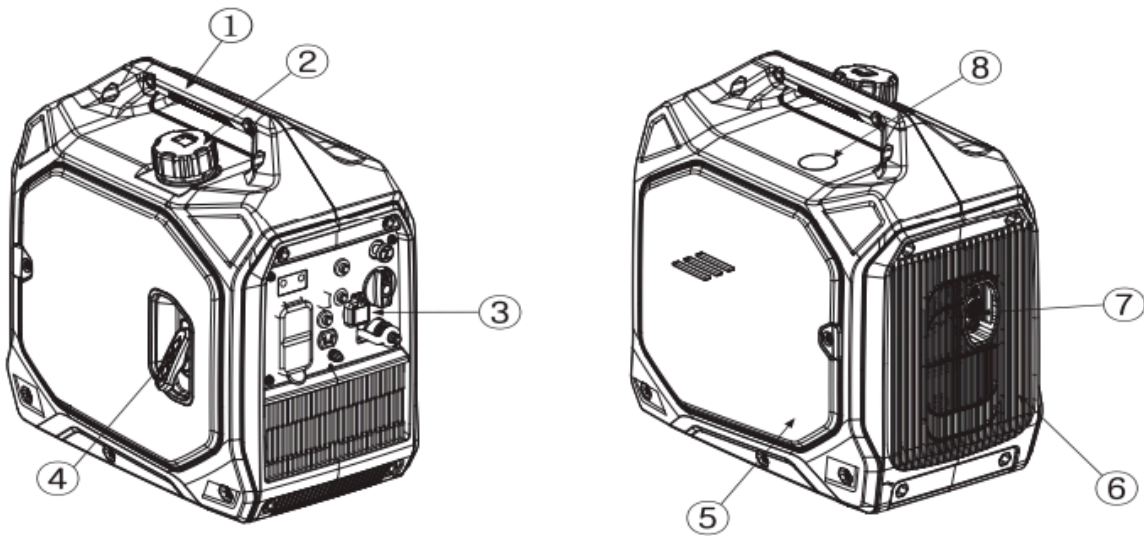

- ① Carrying handle
- ② Fuel tank cap
- ③ Control panel
- ④ Manual starter

- ⑤ Oil tank cap
- ⑥ Grate
- ⑦ Exhaust silencer
- ⑧ Spark plug cover

#### Control panel

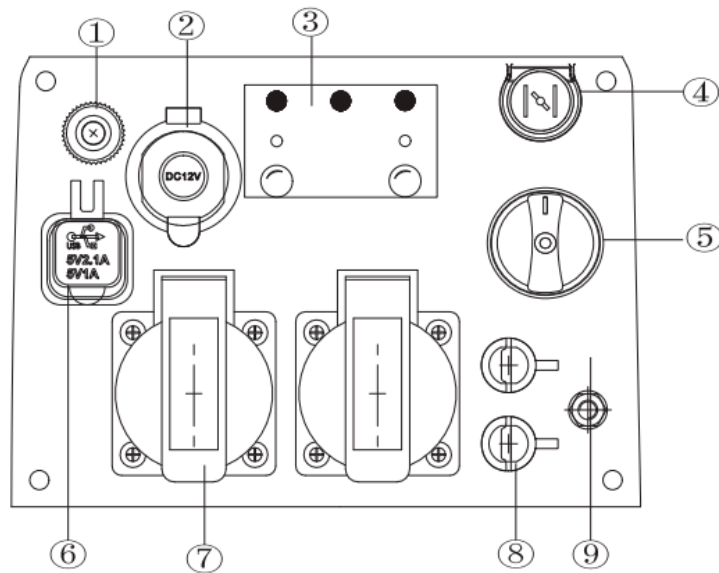



- ① Circuit breaker
- ② DC socket
- ③ ECO and AC reset control panel
- ④ Choke
- ⑤ Fuel valve
- ⑥ USB
- ⑦ AC socket
- ⑧ Sockets for parallel operation
- ⑨ Grounding terminal

## 4. CONTROL FUNCTIONS

### Fuel valve

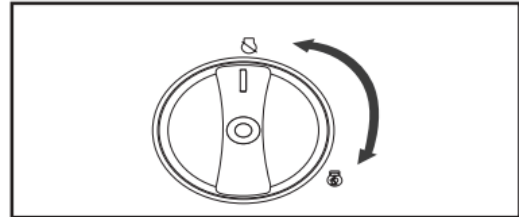
- ① Engine switch \ fuel valve  "OFF";  
The ignition circuit is switched off. Fuel does not flow. The engine will not run.



- ② Engine switch \ fuel valve \ choke  nd "ON";  
The ignition circuit is switched on. Fuel flows. The choke is switched on. The engine can

### Oil indicator light (red)

When the oil level falls below the lower limit, the oil indicator light comes on and the engine stops automatically. If you do not add oil, the engine will not start again.

Tip: If the engine stalls or fails to start, turn the engine switch to the "ON" position and then pull the starter cord.

If the oil indicator light flashes for a few seconds, it means that there is not enough oil in the engine.

Add oil and restart the engine.

### Overload indicator light (red)

The overload indicator light illuminates when an overload is detected in the connected electrical equipment, the inverter control unit overheats, or the output AC voltage increases. The AC protection is then activated, stopping power generation to protect the generator and all connected electrical equipment. The AC power indicator light (green) goes out and the overload indicator light (red) remains lit, but the engine does not stop running.

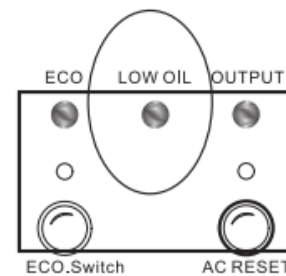

When the overload indicator light comes on and power generation stops, proceed as follows:

- 1) Switch off all connected electrical devices and stop the motor.
- 2) Reduce the total power consumption of the connected electrical devices to the rated power.
- 3) Check that the air intake is not blocked. If you find any blockages, remove them.
- 4) After checking, restart the motor.

Tip: The overload indicator light may illuminate for a few seconds

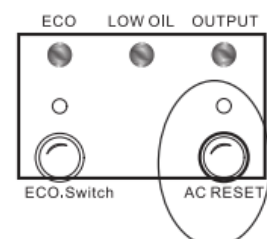

when first using electrical devices that require a high starting current, such as a compressor or submersible pump. However, this is not a malfunction.

### AC indicator light (green)

When the generator is operating normally, the AC indicator light is green. If the generator malfunctions, the AC indicator light flashes red and the machine automatically protects itself and disconnects the output. To reset, press the AC button.



### Intelligent engine control

Pressing the ECO button illuminates the green indicator light and activates economy mode. Pressing the button again deactivates economy mode.

### Grounding terminal

The grounding terminal ① is used to connect a grounding wire to prevent electric shock. If the electrical equipment is grounded, the generator must also be grounded.

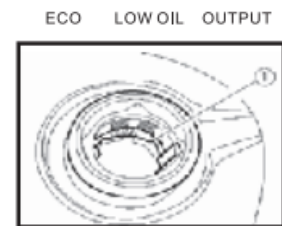

### Fuel tank cap

Unscrew the fuel tank cap by turning it counterclockwise.

## 5. PREPARATION

### Fuel

#### ⚠ DANGER

- Fuel is highly flammable and toxic. Read the "SAFETY INFORMATION" carefully before refuelling.
- Do not overfill the tank, as it may overflow when the fuel heats up and expands.
- After refuelling, ensure that the fuel tank cap is tightened securely.

#### NOTE

- Wipe up spilled fuel immediately with a clean, dry, soft cloth, as fuel can damage painted surfaces or plastic parts.
- Use only unleaded petrol. The use of leaded petrol will cause serious damage to the internal parts of the engine.

Remove the fuel tank cap and fill the tank with fuel up to the red mark.

① Red mark

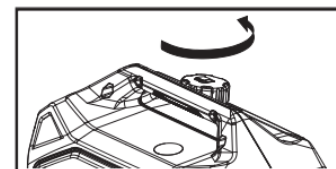
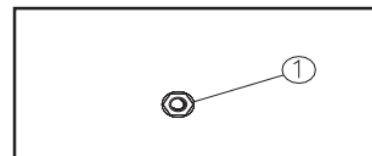
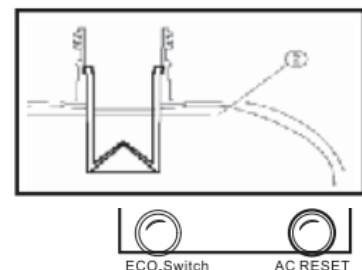

## ② Fuel level

Recommended fuel: Unleaded petrol

Fuel tank capacity: Total: 4.0 l

## Engine oil

### NOTE

The generator was delivered without engine oil. Do not start the engine until you have filled it with sufficient engine oil.

1. Place the generator on a level surface.
2. Remove the screws ① and then remove the cover ②.
3. Remove the oil filler cap ③.

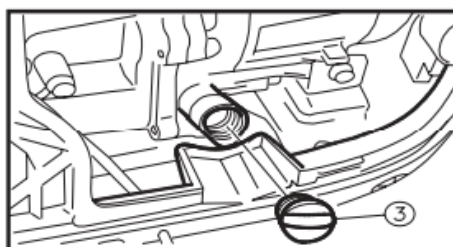
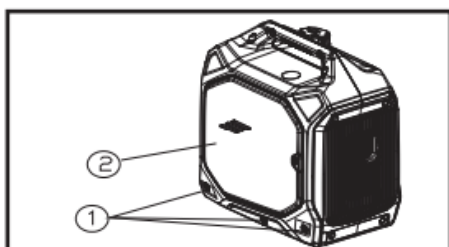

4. Pour in the specified amount of recommended engine oil, then install and tighten the oil tank cap.
5. Install the cover and tighten the screws.

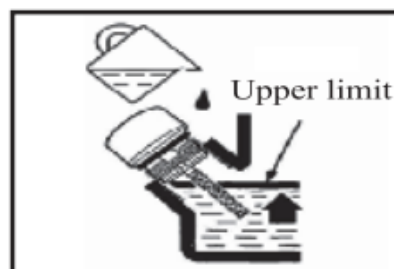
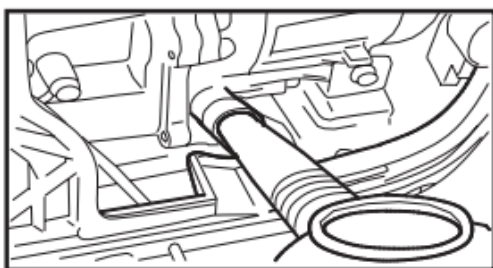

Recommended engine oil: SAE 10W-30

Engine oil quantity: 0.45 l

## PRE-OPERATION CHECK

### WARNING

If any of the items in the pre-operation check do not work properly, have them checked and repaired before operating the generator.

The owner is responsible for the condition of the generator. Important components can wear out quickly and unexpectedly, even when the generator is not in use.

TIP: The pre-operation check should be performed before each use of the generator.

### **Pre-startup check**

#### **Fuel**

- Check the fuel level in the fuel tank.
- Refill with fuel if necessary.

#### **Engine oil**

- Check the oil level in the engine.
- Top up with the recommended oil to the specified level if necessary.
- Check that no oil is leaking from the generator.

#### **Location where the fault was detected during use**

- Check the operation.
- If necessary, top up with the recommended oil to the specified level.
- If necessary, contact an authorised dealer of our company.

## **6. OPERATION**

### **⚠ WARNING**

- Never use the engine in an enclosed space, as this could lead to unconsciousness and death in a short time. Use the engine in a well-ventilated area.
- Do not connect any electrical devices before starting the engine.

### **NOTE**

- The generator is supplied without engine oil. Do not start the engine until you have filled it with sufficient engine oil.
- Do not tilt the generator when refilling the engine oil. This could cause overfilling and damage to the engine.

### **TIP:**

The generator can be used with the rated output load under standard atmospheric conditions.

"Standard atmospheric conditions"

Ambient temperature 25 °C

Barometric pressure 100 kPa

Relative humidity 30%

Generator output varies depending on changes in temperature, altitude (lower air pressure at higher altitudes) and humidity.

Generator output decreases when temperature, humidity and altitude are higher than standard atmospheric conditions.

In addition, it is necessary to reduce the load when using in enclosed spaces, as generator cooling is affected.

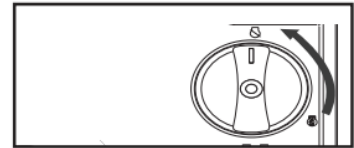
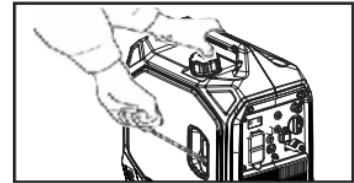

### Starting the engine

1. Set the ECO switch to the "OFF" position ①.

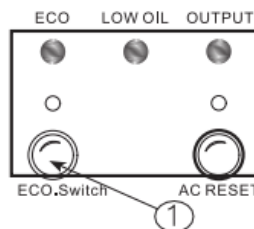

2. Turn off the choke on the panel



**TIP:** It is not necessary to use the choke to start a warm engine.

4. Turn the fuel valve to the "ON" position
  - a. The ignition circuit is switched on.
  - b. The fuel is turned on.

**TIP:** Hold the handle firmly so that the generator does not move when pulling the starter cord.

5. After starting the engine, allow the engine to warm up until it stops when you return the choke knob to the "ON" position.

**TIP:** When starting the engine with ECO "ON" and no load on the generator:

- At ambient temperatures below 0 °C (32 °F), the engine will run at rated speed (4500 rpm) for 5 minutes to warm up.
- At ambient temperatures below 5 °C (41 °F), the engine

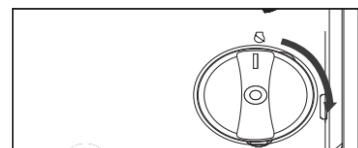

will run at rated speed (4500 rpm) for 3 minutes to warm up.

- The ECO unit will operate normally after the above period has elapsed, provided that ECO is switched on.

### Turning off the motor

**TIP:** Switch off all electrical devices.

1. Turn ECO to the "OFF" position.
2. Disconnect all electrical devices.
3. Turn the fuel valve to the "OFF" position.
  - a. The ignition circuit is switched off.
  - b. The fuel is turned off.

### Connecting alternating current (AC)

#### WARNING

Before connecting electrical equipment, ensure that it is switched off.

#### NOTE

- Before connecting to the generator, ensure that all electrical equipment, including cables and plugs, is in good condition.
- Ensure that the total load does not exceed the generator's rated power.
- Ensure that the load current of the socket is within the rated current of the socket.

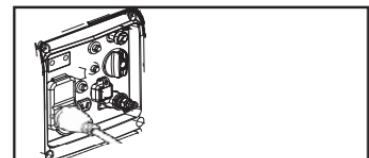
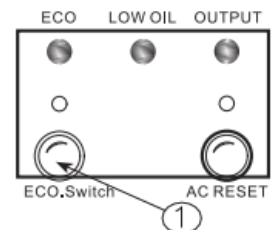

**TIP:** Ensure that the generator is earthed. If the electrical equipment is earthed, the generator must always be earthed as well.

1. Start the engine.
2. Turn the ECO switch to the "ON" position.
3. Plug into the AC socket.
4. Ensure that the AC indicator light is on.
5. Switch on all electrical devices.

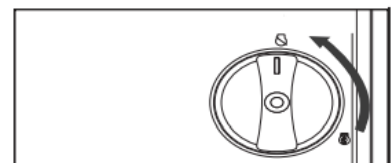

**TIP:** ECO must be set to the "OFF" position to increase the engine speed to the rated speed.

If the generator is connected to multiple loads or electrical appliances, be sure to connect the one with the highest starting current first and the one with the lowest starting current last.

## Charging the battery

### TIP:

- The rated voltage of the DC generator is 12 V.
  - First start the engine and then connect the generator to the battery for charging.
  - Before starting to charge the battery, make sure that the DC protection is switched on.
1. Start the engine.
  2. Connect the red wire of the battery charger to the positive (+) terminal of the battery.
  3. Connect the black lead of the battery charger to the negative (-) terminal of the battery.
  4. Switch off ECO to start charging the battery.

### NOTE

- Ensure that ECO is turned off while charging the battery.
- Ensure that the red lead of the battery charger is connected to the positive (+) terminal of the battery and the black lead is connected to the negative (-) terminal of the battery. Do not reverse these positions.
- Connect the battery charger leads to the battery terminals so that they will not become disconnected due to engine vibration or other disturbances.
- Charge the battery correctly according to the instructions in the battery user manual.
- The DC protection will automatically switch off if the current exceeds the rated value during battery charging. To restart battery charging, press the "ON" button to turn on the DC protection. If the DC protection turns off again, stop charging the battery immediately and contact an authorised dealer of our company.

### TIP:

- Follow the instructions in the battery user manual to determine when the battery is fully charged.



### WARNING

**Never smoke while charging, and do not connect or disconnect the battery.**

**Sparks can ignite gas from the battery.**

**Battery electrolyte is toxic and dangerous, causing severe burns, etc. It contains sulphuric acid. Avoid contact with skin, eyes or clothing.**

**First aid:**

**EXTERNAL – Rinse with water.**

**INTERNAL – Drink plenty of water or milk. Then drink milk with magnesium, beaten egg or vegetable oil. Seek medical attention immediately.**





**EYES: Rinse with water for 15 minutes and seek immediate medical attention.**

**Batteries produce explosive gases. Keep them away from sparks, flames, cigarettes, etc. Ensure ventilation when charging or using in an enclosed space. Always cover your eyes when working near batteries.**

**KEEP OUT OF REACH OF CHILDREN.**

**Scope of use**

When using the generator, ensure that the total load does not exceed the rated power of the generator. Otherwise, the generator may be damaged.

<b>AC</b>				<b>DC</b> 
Power factor	1	0.8-0.95	0 . 4 – 0 . 7 5 (Efficiency 0.85)	
Nominal power	≤2,200 W	≤1,520 W	≤760 W	Nominal voltage 12 V

**TIP:**

- The power consumption of the application indicates when each device is used separately.
- Simultaneous use of AC and DC power is possible, but the total power consumption should not exceed the rated power.

Nominal generator power		2,200 W
Frequency	Efficiency	
AC	1.0	≤ 2, 200W
	0.8	≤ 1, 520W
DC	---	100W (12V / 8.3A)

The overload indicator light ① will illuminate when the total power consumption exceeds the application range.

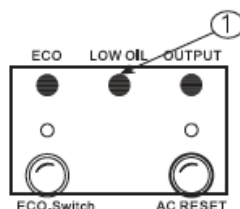

**NOTE**

- Do not overload. The total load of all electrical appliances must not exceed the generator's power range. Overloading will damage the generator.

- When powering precision instruments, electronic control units, computers, electronic calculators, microcomputer-based equipment, or battery chargers, keep the generator at a sufficient distance to prevent electrical interference with the engine. Also, ensure that electrical noise from the engine does not interfere with any other electrical equipment located near the generator.
- If the generator is to power medical equipment, consult the manufacturer, doctor or hospital first.
- Some electrical appliances or universal electric motors have high starting currents and therefore cannot be used, even if they fall within the power range specified in the table above. For more information, contact the equipment manufacturer.

## 7. MAINTENANCE

The engine must be properly maintained to ensure safe, economical and trouble-free operation and to be environmentally friendly.

To keep a petrol engine in good working order, it must be serviced regularly. The following maintenance schedule and routine inspection procedures must be carefully followed:

Items		Frequency	Every	First month or first 20 hours of operation	Then every 3 months or every 50 hours of operation	Every year or every 100 hours of operation
Engine oil	Check – top up		X			
	Replacement			X	X	
Reduction gear oil (if fitted)	Oil level check		X			
	Replacement			X	X	
Air filter	Check		X			
	Cleaning			X		
	Replacement				X	
Collection container (if included)	Cleaning					X
Spark plug	Check – adjustment					X
	Replacement		Every year or after 250 hours of operation			
Spark arrestor	Cleaning				X	
Idling (if included)*	Check – adjustment					X
Valve clearance*	Check – adjustment					X

Fuel tank and fuel filter*	Cleaning				X
Fuel line	Inspection	Every 2 years (replace if necessary)			
Cylinder head, piston	Carbon removal *	$< 225 \text{ cm}^3$ — every 125 hours. $\geq 225 \text{ cm}^3$ — every 250 hours			
*These parts should be maintained and repaired by our authorised dealer if the owner does not have the appropriate tools and is not skilled in mechanical maintenance.					

#### NOTE

- If the petrol engine frequently operates at high temperatures or under heavy loads, change the oil every 25 hours.
- If the engine frequently operates in dusty or other harsh environments, clean the air filter every 10 hours; replace the air filter every 25 hours if necessary.
- The maintenance period and the exact time (hour) are decisive, whichever comes first.
- If you have missed the scheduled engine maintenance date, perform maintenance as soon as possible.

#### ! WARNING

**Stop the engine before performing maintenance. Place the engine on a level surface and remove the spark plug cap to prevent the engine from starting.**

**Do not use the engine in poorly ventilated rooms or other enclosed spaces. Ensure good ventilation in the work area.**

**Engine exhaust gases may contain poisonous CO, which can cause shock, unconsciousness or even death if inhaled.**

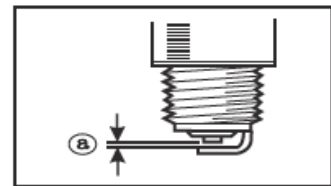

#### Checking the spark plug

The spark plug is an important part of the engine that needs to be checked regularly.

1. Remove the cover ① and use tool ③ to remove the spark plug cap ②, then insert tool ⑤ into the hole from the outside of the cover.

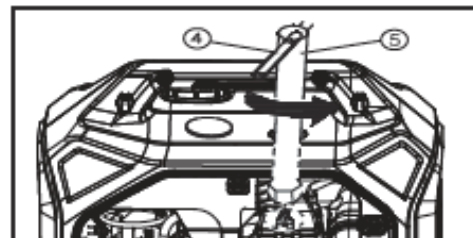
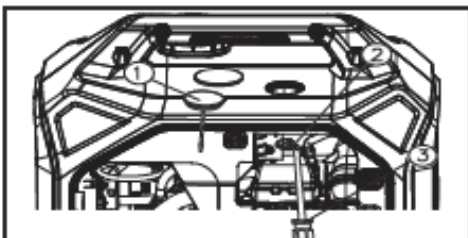

2. Insert the handle ④ into the tool ⑤ and turn them counterclockwise to remove the spark plug.

3. Check for discolouration and remove any carbon deposits. The porcelain insulator around the centre electrode of the spark plug should be medium to light brown in colour.
4. Check the spark plug type and gap.

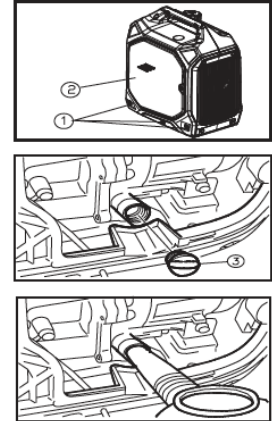

Standard spark plug:  
TORCH-A5RTC  
Spark plug electrode gap: **0.6–0.8 mm**

**TIP:** The gap between the spark plug electrodes should be measured using a wire gauge and adjusted to specification if necessary.

5. Install the spark plug.

Spark plug torque: **12.5 N·m (1.25 kgf·m, 9 lbf·ft)**

**TIP:** If you do not have a torque wrench available when installing the spark plug, the correct tightening torque can be estimated at **1/4–1/2 turn after tightening with your fingers**. However, the spark plug should be tightened to the specified torque as soon as possible.

6. Install the spark plug cap and spark plug cover.

### Carburettor adjustment

The carburettor is an important part of the engine. Adjustment should be entrusted to an authorised dealer of our company, who has the expertise, specialised data and equipment to perform it correctly.

### Engine oil change



Do not drain the engine oil immediately after stopping the engine. The oil is hot and must be handled with care to avoid burns.

1. Place the generator on a level surface and warm up the engine for a few minutes. Then stop the engine and turn the **fuel tank cap vent knob** to the "OFF" position.

2. Remove the screws ① and remove the cover ②.
3. Remove the oil filler cap ③.
4. Place an oil pan under the engine. Tilt the generator to drain all the oil.
5. Return the generator to a level surface.

#### **NOTE**

Do not tilt the generator when adding engine oil. This could cause overfilling and damage to the engine.

6. Fill with engine oil up to the upper mark.

Recommended engine oil: **SAE 10W-30**

Engine oil quantity: **0.4 l**

7. Clean the cover and wipe up any spilled oil.

#### **NOTE**

Ensure that no foreign objects enter the crankcase.

8. Refit the oil filler cap.
9. Refit the cover and tighten the screws.

#### **Air filter**

1. Remove the screws ① and then remove the cover ②.
2. Remove the air filter housing cover ③.

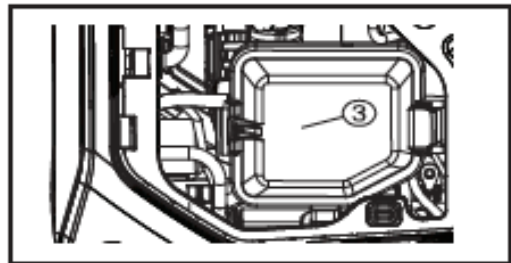
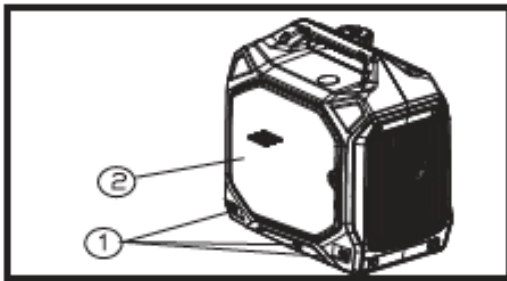

3. Remove the foam element ⑤.
4. Wash the foam element in solvent and dry it.
5. Lubricate the foam element with oil and squeeze out any excess oil. The foam element should be wet, but oil should not drip from it.

#### **NOTE**

**Do not wring out the foam element when squeezing out the oil. This could cause it to tear.**

1. Insert the foam element into the air filter housing.

**TIP:** Ensure that the sealing surface of the foam element matches the air filter to prevent air leakage.

**The engine should never be run without the foam element; this could cause excessive wear on the piston and cylinder.**

1. Install the air filter housing cover in its original position and tighten the screw.

2. Fit the cover and tighten the screws.

### Exhaust silencer screen and spark arrestor



#### WARNING

After running the engine, the engine and exhaust muffler will be very hot. During inspection or repair, do not touch the engine and exhaust muffler with any part of your body or clothing while they are hot.

1. Remove the screws ①, then pull out the cover areas ② shown in the illustration.

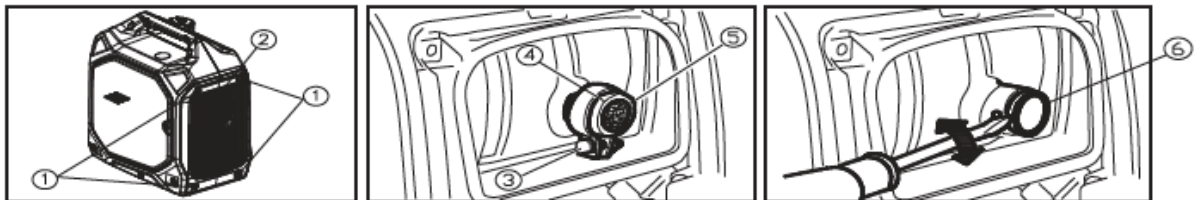
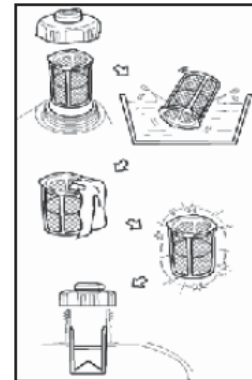

2. Loosen screw ③, then remove the muffler cover ④, muffler screen ⑤, and spark arrestor ⑥.
3. Clean the carbon deposits on the exhaust silencer screen and spark arrestor using a wire brush.

#### NOTE

When cleaning, use the wire brush gently to avoid damaging or scratching the muffler screen and spark arrestor.

4. Check the exhaust silencer screen and spark arrestor. If they are damaged, replace them.
5. Install the spark arrestor.

#### TIP

Align the protrusion of the spark arrestor ⑦ with the hole ⑧ in the muffler pipe.

1. Install the exhaust silencer screen and exhaust silencer cover.
2. Install the cover and tighten the screws.

### Fuel tank filter



Never use petrol while smoking or near an open flame.

1. Remove the fuel tank cap and filter.
2. Clean the filter with petrol.
3. Wipe the filter and install it.
4. Replace the fuel tank cap.

Ensure that the fuel tank cap is tightly secured.

### Fuel filter

1. Unscrew the screws ①, remove the cover ② and drain the fuel ③.

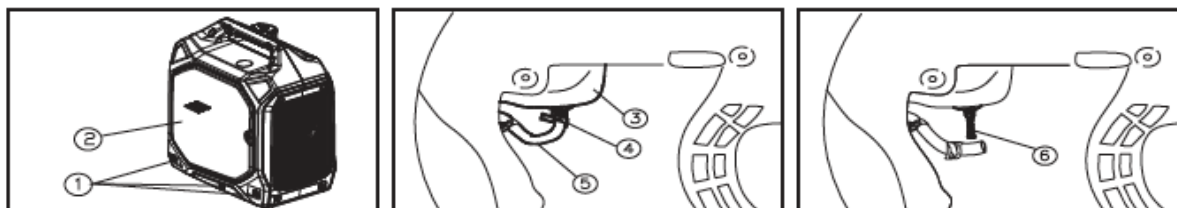

2. Hold and slide the clamp ④ upwards, then remove the hose ⑤ from the tank.
3. Remove the fuel filter ⑥.
4. Clean the filter with petrol.
5. Dry the filter and put it back into the tank.
6. Refit the hose and clamp, then open the fuel valve to check for leaks.
7. Refit the cover and tighten the screws.

## 8. STORAGE

Long-term storage of the machine requires certain preventive measures to prevent damage.

### Drain the fuel

1. Turn the fuel valve to the "OFF" position.



2. Remove the fuel tank cap and remove the filter. Drain the fuel from the fuel tank into a suitable petrol container. Then install the fuel tank cap.



### **WARNING**

**Fuel is highly flammable and toxic. Carefully read the "SAFETY INFORMATION"**

### **NOTE**

**Immediately wipe up any spilled fuel with a clean, dry, soft cloth, as fuel can damage painted surfaces or plastic parts.**

3. Start the engine and let it run until it stops. The engine will stop in approximately 20 minutes. The time is measured by fuel consumption.

### **TIP:**

- Do not connect any electrical equipment. (no-load operation)
  - The engine running time depends on the amount of fuel remaining in the tank.
4. Unscrew the screws and remove the cover.
  5. Drain the fuel from the carburettor by loosening the drain screw on the carburettor float chamber.
  6. Turn the fuel valve to the "OFF" position.
  7. Tighten the drain screw.
  8. Replace the cover and tighten the screws.
  9. After the engine has cooled completely, turn the fuel tank cap vent knob to the "OFF" position.

### **Engine**

Perform the following steps to protect the cylinder, piston ring, etc. from corrosion.

1. Remove the spark plug, pour about one tablespoon of **SAE 10W-30** oil into the spark plug hole, and reinstall the spark plug. Start the engine several times by turning the starter cord (with the 3-in-1 switch turned off) to coat the cylinder walls with oil.
2. Pull the starter cord until you feel compression. Then stop pulling. (This will prevent corrosion of the cylinder and valves).
3. Clean the outside of the generator. Store the generator in a dry, well-ventilated place and cover it with a cover.

## 9. TROUBLESHOOTING

The engine will not start

### 1. Fuel systems

No fuel is being supplied to the combustion chamber.

- There is no fuel in the tank... Refill the fuel tank.
- There is fuel in the tank... Turn the fuel tank vent valve and fuel tap to the "ON" position.
- Clogged fuel filter... Clean the fuel filter.
- Clogged carburettor... Clean the carburettor.

### 2. Engine oil system

Insufficient

- Low oil level... Top up the engine oil.

### 3. Electrical systems

- Set switch 1 in 3 to the "CHOKE" position and pull the starter cord... Weak spark.
- The spark plug is fouled with carbon or wet... Remove the carbon or wipe the spark plug dry.
- Faulty ignition system... Contact an authorised dealer of our company.

Generator does not produce power

- Safety device (DC circuit breaker) is in the "OFF" position ... Switch the DC circuit breaker to the "ON" position.
- The AC indicator light (green) has gone out ... Stop the engine and restart it.

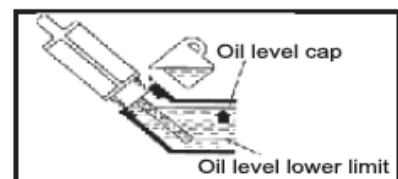

## 10. SPECIFICATIONS

Model		
Generator	Type	Inverter
	Nominal frequency (Hz)	50
	Nominal voltage (V)	230
	Nominal output power (kW)	2.2
	Power factor	1
	AC output quality	ISO8528 G2
	Charging voltage (DC) (V)	12
	Charging current (DC) (A)	20, 18.3, 10, 9.6, 9.2
	Overload protection (DC)	Protection without fuse
	Compliant with Directives 2000/14/EC and 2005/88/EC Guaranteed acoustic power: <b>90 dBA</b> Acoustic pressure emission level: <b>68 dBA</b>	
Motor	Engine	R100-i4
	Engine type	Single cylinder, four-stroke, air-cooled, OHV
	Displacement (cc)	100
	Fuel type	Unleaded petrol
	Fuel tank capacity (l)	4
	Continuous operating time (at rated power) (h)	3.5
	Oil capacity (l)	0.4
	Ignition model number	TORCH-A5RTC
	Starting method	Manual starter
Power generator	Length × width × height (mm)	445 × 290 × 440
	Net weight (kg)	19

# 11. WIRING DIAGRAM

